

3

4

5

6

7

8

$\phi 3.05 \pm 0.05$

$\phi 10.0 \pm 0.1$

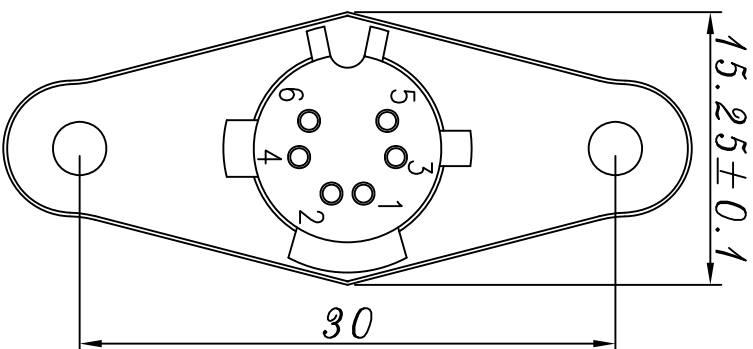
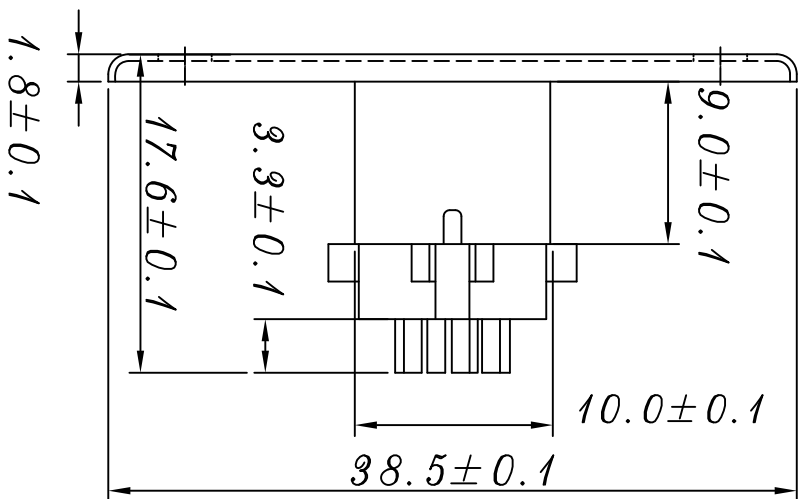

MATERIALS:

HOUSING: NY6+FB (PA-1010C2)

METAL SHELL: IRON PLATE/NICKEL PLATED

CONTACTS: PHOSPHOR BRANZESILVER PLATED

SPECIFICATIONS:

1. RATION: 100V AC 1A MAX or 12V DC 2A MAX.
2. INSULATION RESISTANCE: 50M OHM MIN at 250V DC.
3. DIELECTRIC STRENGTH: 250 V AC / 1 MINUTE.
4. CONTACT RESISTANCE: 30M OHM MAX.
5. INSERTION FORCE: 4.5KG MAX.
6. WITHDRAWAL FORCE: 0.9KG ~ 3KG.

大廣有限公司
DA KOANG CO., LTD.

TOLERANCES

.X ± 0.1 .XXX ±
.XX ± 0.2 ANGLES

PART NUMBER

2007 SERIES

SCALE

mm

DESCRIPTION

MINI DIN SOCKET
METAL PANEL MT

CHECK

JANNE HUNG

REV.

∅

DRAFT

W.RAY 111710'

APPROVAL

DANNY HSU

SHEET

1 / 1