

A B C D E

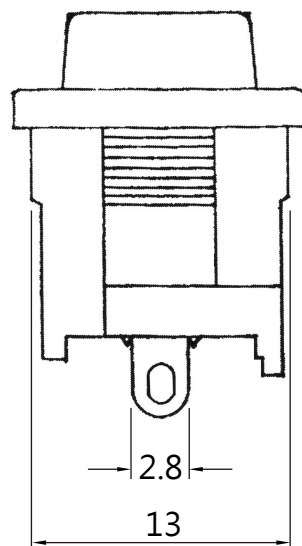
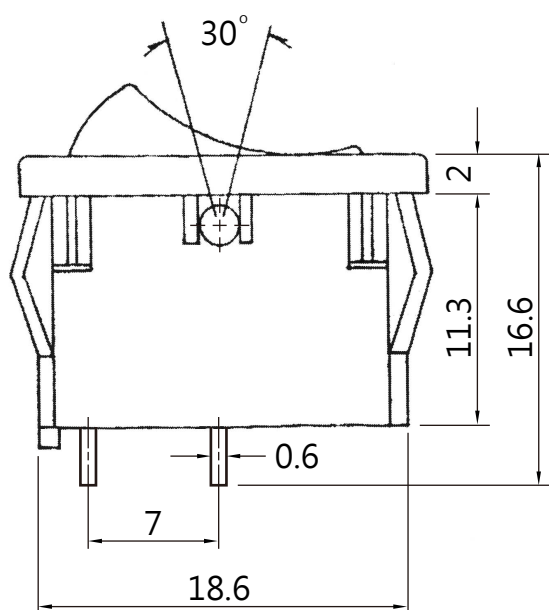
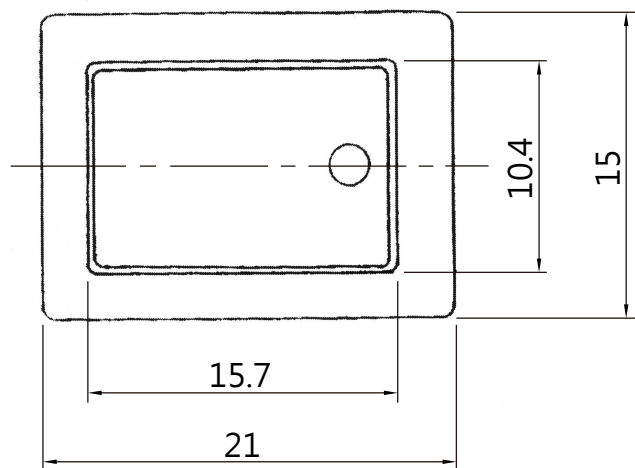

Specifications:

1. Rating : 6A 125VAC/3A 250VAC
2. Contact Resistance : 2.5VDC 1A 20mΩ (max)
3. Insulation Resistance : 500VDC 100MΩ (min)
4. Dielectric Strength : 1000VAC/1 Minute
5. 2P (SPST) 電木底
6. (ON)-OFF

大廣有限公司 DA KOANG CO., LTD.

DATE	DWN	CHKD	APVD	MANAGER
12.08.2005				

PART NAME: 2P ROCKER SWITCH

PART NUMBER: 5009A

VERSION:2.0

TOLERANCE :±0.3mm UNLESS OTHERWISE SPECIFIED

UNIT:mm



SCALE:

A B C D E