

材質表

NO.	部品名稱 PART NAME	部品材質 MATERIAL
1	本體 HOSING	壓克力 ACRYLIC
2	螺母 NUT	青銅 BRONZE
3	華司 WASHER	鐵圈 IRON HOOP
4	底座 HOLDER	尼龍66+玻璃纖維
5	焊片 SOLDER	青銅 BRONZE
6	燈泡 LAMP	6X12+1/4W電阻

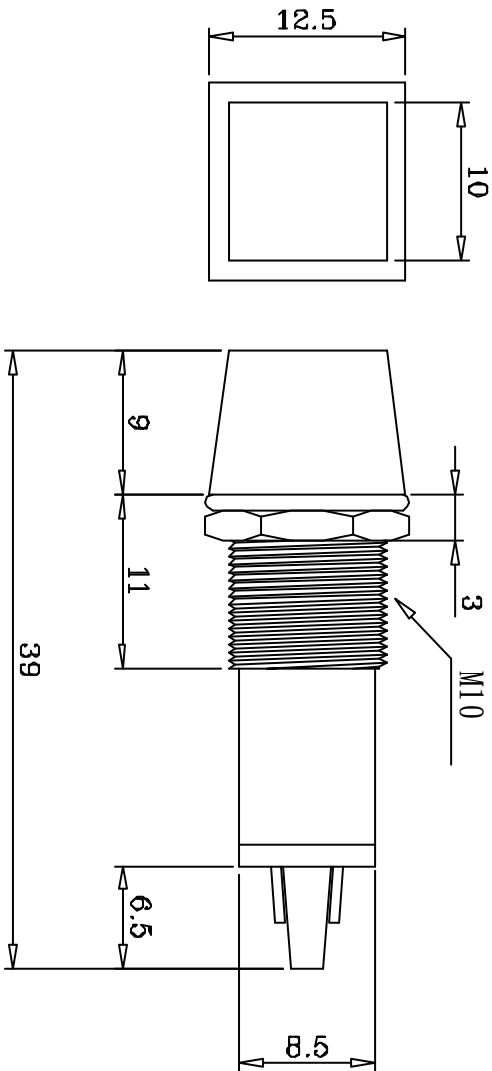

MODEL NO.

LAMP COLOR

<input type="checkbox"/>	8010A-R	110V	RED
<input type="checkbox"/>	8010A-Y	110V	YELLOW
<input type="checkbox"/>	8010A-G	110V	GREEN
<input type="checkbox"/>	8010B-R	220V	RED
<input type="checkbox"/>	8010B-Y	220V	YELLOW
<input type="checkbox"/>	8010B-G	220V	GREEN
<input type="checkbox"/>	8010C-R	12V	RED
<input type="checkbox"/>	8010C-Y	12V	YELLOW
<input type="checkbox"/>	8010C-G	12V	GREEN
<input type="checkbox"/>	8010D-R	24V	RED
<input type="checkbox"/>	8010D-Y	24V	YELLOW
<input type="checkbox"/>	8010D-G	24V	GREEN

大廣有限公司
DA KOANG CO., LTD.

INDICATOR LIGHT



Title
Dwg No. 8010
File No.

Scale: 2 : 1
Size: A 4

Approver:

Checker:

Drawer:

Rev : 0-1
Sheet: 1 / 1