

材質表

NO.	部品名稱 PART NAME	部品材質 MATERIAL
1	本體 HOSING	壓克力 ACRYLIC
2	螺母 NUT	青銅 BRONZE
3	華司 WASHER	塑膠 Plastics
4	底座 HOLDER	尼龍66+玻璃纖維
5	焊片 SOLDER	青銅 BRONZE
6	燈泡 LAMP	6X12+1/4W電阻

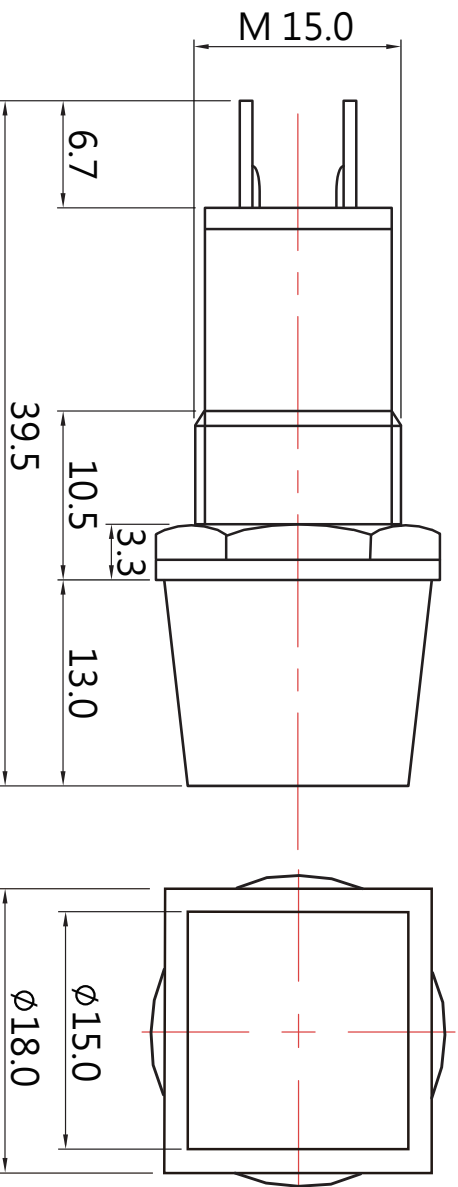

MODEL NO. LAMP COLOR

<input type="checkbox"/>	8011A-R 110V	RED
<input type="checkbox"/>	8011A-Y 110V	YELLOW
<input type="checkbox"/>	8011A-G 110V	GREEN
<input type="checkbox"/>	8011B-R 220V	RED
<input type="checkbox"/>	8011B-Y 220V	YELLOW
<input type="checkbox"/>	8011B-G 220V	GREEN
<input type="checkbox"/>	8011C-R 12V	RED
<input type="checkbox"/>	8011C-Y 12V	YELLOW
<input type="checkbox"/>	8011C-G 12V	GREEN

大廣有限公司
DA KOANG CO., LTD.

INDICATOR LIGHT



Title
Dwg No. 8011
File No.

Scale: 2 : 1

Size: A 4

Approver:

Checker:

Drawer:

Rev : 0-1

Sheet: 1 / 1

WF00-4C